



Installation, Operation & Maintenance

HWW Series

**Commercial Water-to-Water
Water-Source Heat Pumps**

Table of Contents

Model Nomenclature	3
General Information	4-5
Unit Physical Data	6
HWW036-120 – Unit Dimensional Data	7
Unit Installation	8
Piping Installation	9
Load Plumbing Installation	9
Water-Loop Heat Pump Applications	10
Ground-Water Heat Pump Applications	11-12
Ground-Loop Heat Pump Applications	13-14
Water Quality Standards	15-18
Electrical – Line Voltage	19
Electrical Data	19
Electrical – Low Voltage	20
Electrical – Accessories	21
Electrical – Line Voltage	22
Electrical – Low Voltage	23
HWW Series Wiring Diagram Matrix	24
Piping System Cleaning & Flushing	25
Controls - CXM2 & DXM2.5	26
Unit & System Checkout	27
Unit Start Up Procedure	28
Operating Pressures	29-30
Preventative Maintenance	31
Start-Up Log Sheet	32
Refrigeration Troubleshooting Form	33
Revision History	36

Model Nomenclature

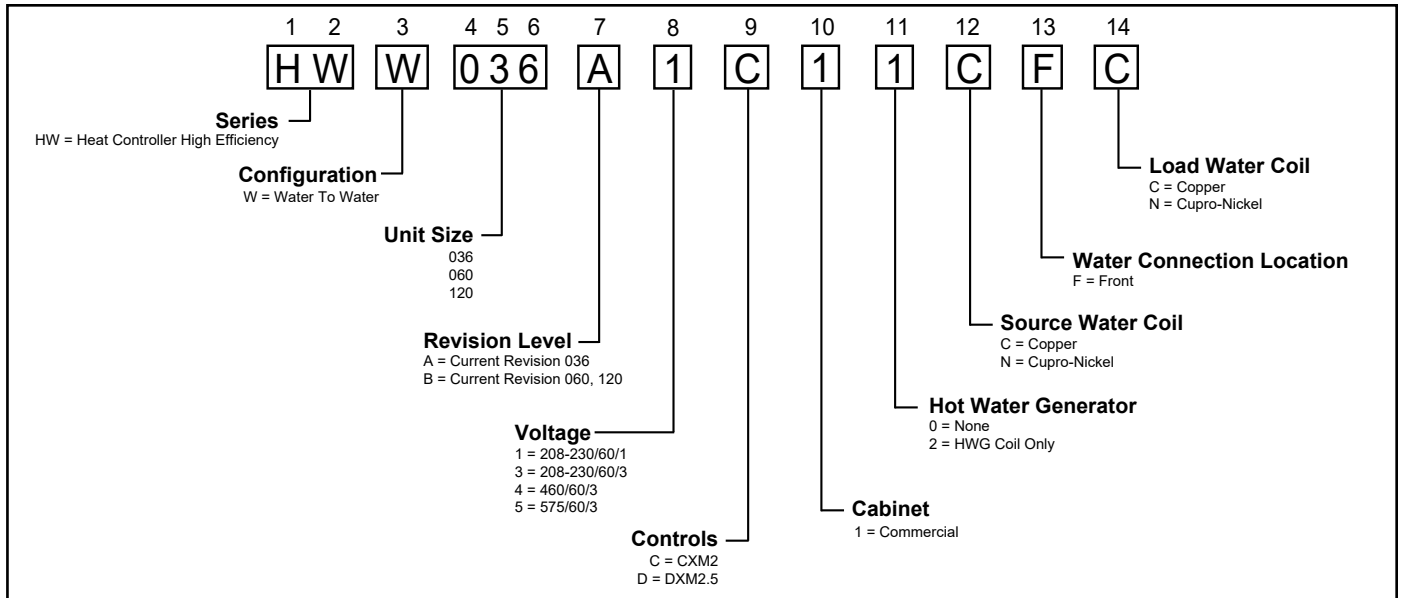

General Information

Safety

Warnings, cautions, and notices appear throughout this manual. Read these items carefully before attempting any installation, service, or troubleshooting of the equipment.

DANGER: Indicates an immediate hazardous situation, which if not avoided will result in death or serious injury. DANGER labels on unit access panels must be observed.

WARNING: Indicates a potentially hazardous situation, which if not avoided could result in death or serious injury.

CAUTION: Indicates a potentially hazardous situation or an unsafe practice, which if not avoided could result in minor or moderate injury or product or property damage.

NOTICE: Notification of installation, operation, or maintenance information, which is important, but which is not hazard-related.

WARNING!

WARNING! To avoid the release of refrigerant into the atmosphere, the refrigerant circuit of this unit must be serviced only by technicians who meet local, state, and federal proficiency requirements.

WARNING!

WARNING! All refrigerant discharged from this unit must be recovered **WITHOUT EXCEPTION**. Technicians must follow industry accepted guidelines and all local, state, and federal statutes for the recovery and disposal of refrigerants. If a compressor is removed from this unit, refrigerant circuit oil will remain in the compressor. To avoid leakage of compressor oil, refrigerant lines of the compressor must be sealed after it is removed.

WARNING!

WARNING! The installation of water-source heat pumps and all associated components, parts, and accessories which make up the installation shall be in accordance with the regulations of ALL authorities having jurisdiction and **MUST** conform to all applicable codes. It is the responsibility of the installing contractor to determine and comply with ALL applicable codes and regulations.

CAUTION!

CAUTION! To avoid equipment damage, **DO NOT** use these units as a source of heating or cooling during the construction process. The mechanical components and filters can quickly become clogged with construction dirt and debris, which may cause system damage and void product warranty.

General Information, Cont'd.

Inspection - Upon receipt of the equipment, carefully check the shipment against the bill of lading. Make sure all units have been received. Inspect the carton or crating of each unit, and inspect each unit for damage. Assure the carrier makes proper notation of any shortages or damage on all copies of the freight bill and completes a common carrier inspection report. Concealed damage not discovered during unloading must be reported to the carrier within 15 days of receipt of shipment. If not filed within 15 days, the freight company can deny the claim without recourse. Note: It is the responsibility of the purchaser to file all necessary claims with the carrier. Notify the Heat Controller Traffic Department of all damage within fifteen (15) days of shipment.

Storage - Equipment should be stored in its original packaging in a clean, dry area. Store units in an upright position at all times. The stack limit for HWW036, 060 and 120 is three.

Unit Protection - Cover units on the job site with either shipping packaging, vinyl film, or an equivalent protective covering. Cap the open ends of pipes stored on the job site. In areas where painting, plastering, and/or spraying has not been completed, all due precautions must be taken to avoid physical damage to the units and contamination by foreign material. Physical damage and contamination may prevent proper start-up and may result in costly equipment clean-up.

Examine all pipes, fittings, and valves before installing any of the system components. Remove any dirt or trash found in or on these components.

Pre-Installation - Installation, Operation, and Maintenance instructions are provided with each unit. The installation site chosen should include adequate service clearance around the unit. Before unit start-up, read all manuals and become familiar with the unit and its operation. Thoroughly check the system before operation. Prepare units for installation as follows:

1. Compare the electrical data on the unit nameplate with ordering and shipping information to verify that the correct unit has been shipped.
2. Keep the cabinet covered with the shipping packaging until installation is complete and all plastering, painting, etc. is finished.
3. Verify refrigerant tubing is free of kinks or dents and that it does not touch other unit components.
4. Inspect all electrical connections. Connections must be clean and tight at the terminals.

CAUTION!

CAUTION! All three phase scroll compressors must have direction of rotation verified at start-up. Verification is achieved by checking compressor Amp draw. Amp draw will be substantially lower compared to nameplate values. Additionally, reverse rotation results in an elevated sound level compared to correct rotation. Reverse rotation will result in compressor internal overload trip within several minutes. Verify compressor type before proceeding.

CAUTION!

CAUTION! DO NOT store or install units in corrosive environments or in locations subject to temperature or humidity extremes (e.g., attics, garages, rooftops, etc.). Corrosive conditions and high temperature or humidity can significantly reduce performance, reliability, and service life. Always move and store units in an upright position. Tilting units on their sides will cause equipment damage.

CAUTION!

CAUTION! CUT HAZARD - Failure to follow this caution may result in personal injury. Sheet metal parts may have sharp edges or burrs. Use care and wear appropriate protective clothing, safety glasses and gloves when handling parts and servicing heat pumps.

Unit Physical Data

Model	036	060	120
Compressor (qty)	Scroll (1)		Scroll (2)
Factory Charge R410A (lbs) [kg] / Circuit	4.5 [2.04]	5.5 [2.49]	5.5 [2.49]
Indoor / Load Water connection sizes FPT (in)	3/4"	1"	1-1/2"
Outdoor / Source Water connection Size FPT (in)	3/4"	1"	1-1/2"
HWG Water In/Out IPT (in)	1/2"		
Weight - Operating (lbs) [kg]	348 [158]	360 [163]	726 [329]
Weight - Shipping (lbs) [kg]	373 [169]	385 [175]	770 [349]
Water Volume (Source)			
Gallons (Liters)	0.96 (3.64)	1.33 (5.04)	2.65 (10.02)

Dual isolated compressor mounting
 Balanced port expansion valve (TXV)
 Compressor on (green) and fault (red) light

Dual isolated compressor mounting
 Balanced port expansion valve (TXV)
 Insulated Source and Load Water Coils standard
 Insulated Refrigerant Circuit standard
 Compressor on (green) and fault (red) light

Unit Maximum Water Working Pressure	
Options	Max Working Pressure PSIG [kPa]
Base Unit	300 [2,068]
Motorized Valves	400 [2,758]

HWW036-120 – Unit Dimensional Data

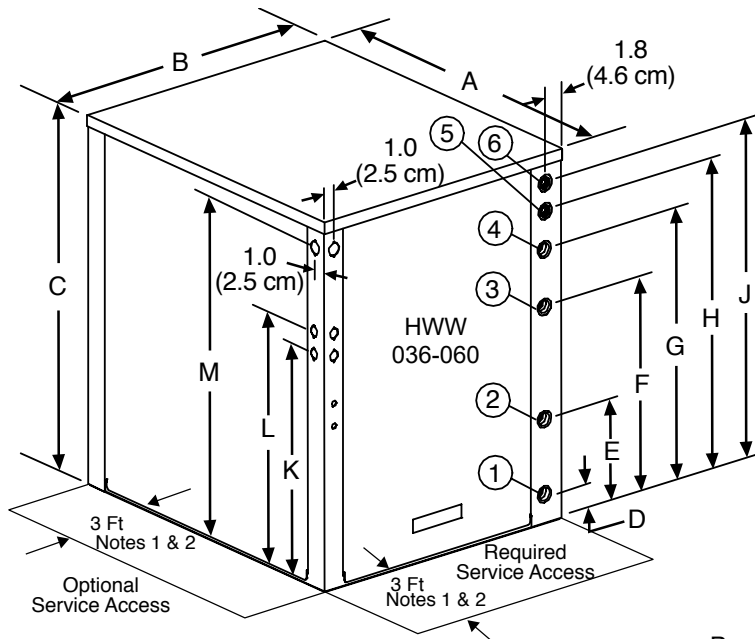

Notes:

1. Front & side access is preferred for service access. However, all components may be serviced from the front access panel if side access is not available.
2. While clear access to all removable panels is not required, installer should take care to comply with all building codes and allow adequate clearance for future field services.

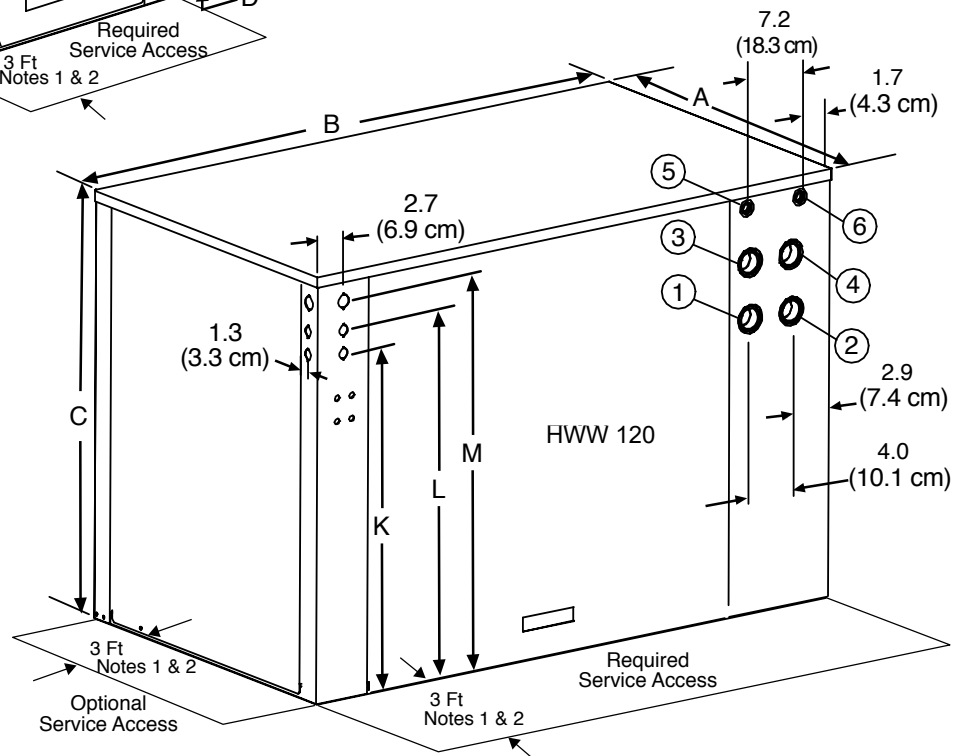

Water to Water	Overall Cabinet			Water Connections						Electric Access Plugs			
				1	2	3	4	5	6				
	A Depth	B Width	C Height	D Source (Outdoor) Water In	E Source (Outdoor) Water Out	F Load (Indoor) Water In	G Load (Indoor) Water Out	H HWG Water In	J HWG Water Out	K Low Voltage	L External Pump	M Power Supply	
036-060	in.	30.6	25.4	33	2.7	9.4	19.4	24.5	27.9	30.4	20.9	22.9	30.9
	cm.	77.8	64.5	83.8	6.9	23.9	49.3	62.2	70.9	77.2	53.1	58.2	78.5
120	in.	30.6	52.9	37	25.2	25.2	30.1	30.1	34.9	34.9	29.9	31.9	34.4
	cm.	77.8	134.4	94	64.0	64.0	76.5	76.5	88.6	88.6	75.9	81.0	87.4

Unit Installation

HWW Unit Location - These units are not designed for outdoor installation. Locate the unit in an INDOOR area that allows enough space for service personnel to perform typical maintenance or repairs.

The installation of water source heat pump units and all associated components, parts and accessories which make up the installation shall be in accordance with the regulations of ALL authorities having jurisdiction and MUST conform to all applicable codes. It is the responsibility of the Installing Contractor to determine and comply with ALL applicable codes and regulations.

Locate the unit in an indoor area that allows easy removal of access panels, and has enough space for service personnel to perform maintenance or repair. Provide sufficient room to make water and electrical connections.. Any access panel screws that would be difficult to remove after the unit is installed should be removed prior to setting the unit. These units are not approved for outdoor installation and, therefore, must be installed inside the structure being conditioned. Do not locate in areas where ambient conditions are not maintained within 40-100°F [4-38°C].

PIPING INSTALLATION

Installation of Supply and Return Piping

Follow these piping guidelines.

1. Install a drain valve at the base of each supply and return riser to facilitate system flushing.
2. Install shut-off / balancing valves and unions at each unit to permit unit removal for servicing.
3. Place strainers at the inlet of each system circulating pump.
4. Select the proper hose length to allow slack between connection points. Hoses may vary in length by +2% to -4% under pressure.
5. Exceeding the minimum bend radius may cause the hose to collapse which reduces water flow rate. Install an angle adapter to avoid sharp bends in the hose when the radius falls below the required minimum and causes a slight kink.

Note: When anti-freeze is used in the loop, assure that it is compatible with Teflon tape or pipe joint compound employed.

Maximum allowable torque for brass fittings is 30 ft-lbs [41 N-m]. If a torque wrench is not available, tighten finger-tight plus one quarter turn. Tighten steel fittings as necessary.

WARNING!
WARNING! Piping must comply with all applicable codes.
WARNING!
WARNING! Do not bend or kink supply lines or hoses.

Insulation is not required on loop water piping except where the piping runs through unheated areas or outside the building or when the loop water temperature is below the minimum expected dew point of the pipe ambient temperature. **Insulation is required if loop water temperature drops below the dew point.**

Pipe joint compound is not necessary when Teflon threaded tape is pre-applied to hose assemblies or when flared-end connections are used. If pipe joint compound is preferred, use compound only in small amounts on the pipe threads of the fitting adapters. Prevent sealant from reaching the flared surfaces of the joint.

Piping Installation

! WARNING! !

WARNING! Polyolester Oil, commonly known as POE oil, is a synthetic oil used in many refrigeration systems including those with HFC-410A refrigerant. POE oil, if it ever comes in contact with PVC or CPVC piping, may cause failure of the PVC/CPVC. PVC/CPVC piping should never be used as supply or return water piping with water source heat pump products containing HFC-410A as system failures and property damage may result.

! CAUTION! !

CAUTION! Corrosive system water requires corrosion resistant fittings and hoses and possibly water treatment.

Optional pressure-rated hose assemblies designed specifically for use with Heat Controller units are available. Similar hoses can be obtained from alternate suppliers. Supply and return hoses are fitted with swivel-joint fittings at one end to prevent kinking during installation.

Refer to Figure 1 for an illustration of a Supply/Return Hose Kit. Male adapters secure hose assemblies to the unit and risers. Install hose assemblies properly and check them regularly to avoid system failure and reduced service life.

Figure 1: Supply/Return Hose Kit

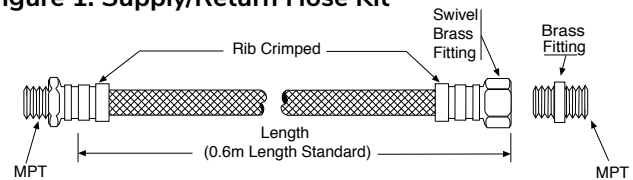

LOAD PLUMBING INSTALLATION

HWW Unit Load Plumbing - The applications are too varied to describe in this document. However, some basic guidelines will be presented. Much of the discussions on water loop applications would be valid for the load plumbing discussion as well. All plumbing should conform to local codes with the following considerations:

Wide temperature variation applications such as heating/cooling coils:

- Employ piping materials that are rated for the maximum temperature and pressure combination. This excludes PVC for most heating applications.
- Insure that load water flow in high temperature heating applications is at least 3 gpm per ton [3.9 l/m per kW] to improve performance and reduce nuisance high pressure faults.
- DO NOT employ plastic to metal threaded joints
- Utilize a pressure tank and air separator vent system to equalize pressure and remove air.

Swimming Pool Hot Tub Applications:

- Load coax should be isolated with secondary heat exchanger constructed of anti-corrosion material in all chlorine/bromine fluid applications.

Potable Water Applications:

- Potable water systems require field supplied external secondary heat exchanger.
- Insure load water flow in high temperature heating applications is at least 3 gpm per ton to improve performance & reduce nuisance to high pressure faults.

Note: The manufacturer strongly recommends all piping connections, both internal and external to the unit, be pressure tested by an appropriate method prior to any finishing of the interior space or before access to all connections is limited. Test pressure may not exceed the maximum allowable pressure for the unit and all components within the water system. The manufacturer will not be responsible or liable for damages from water leaks due to inadequate or lack of a pressurized leak test, or damages caused by exceeding the maximum pressure rating during installation.

Figure 2: Typical Water Loop Application

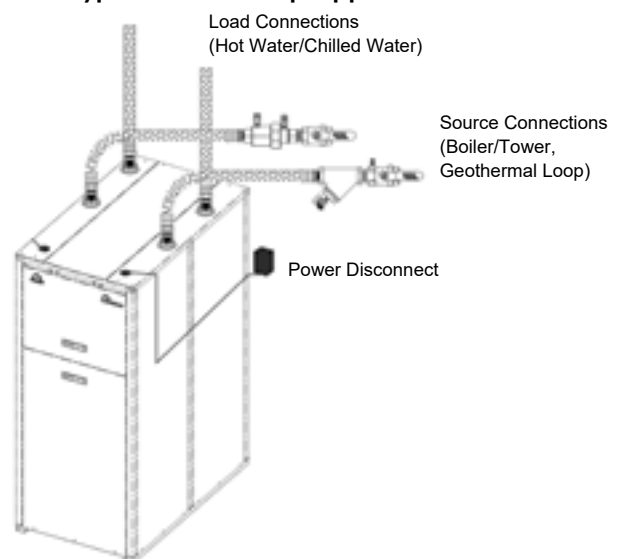

Water-Loop Heat Pump Applications

Commercial systems typically include a number of units plumbed to a common piping system. Any unit plumbing maintenance work can introduce air into the piping system, therefore air elimination equipment is a major portion of the mechanical room plumbing. In piping systems expected to utilize water temperatures below 50°F [10°C], 1/2" [13mm] closed cell insulation is required on all piping surfaces to eliminate condensation. Metal to plastic threaded joints should never be employed due to their tendency to leak over time. Teflon tape thread sealant is recommended for FPT water connections (commercial class) to minimize internal fouling of the heat exchanger. Do not overtighten connections and route piping so as not to interfere with service or maintenance access. Hose kits are available from Heat Controller in different configurations as shown in Figure 2 for connection between the HWW Series and the piping system. The hose kits include shut off valves, P/T plugs for performance measurement, high pressure stainless steel braid hose, "Y" type strainer 20 mesh (841 micron) [0.84mm] with blowdown valve, and "J" type swivel connection. Balancing valves to facilitate the balancing of the system, and an external low pressure drop solenoid valve for use in variable speed pumping systems, may also be included in the hose kit. The piping system should be flushed to remove dirt, piping chips, and other foreign material prior to operation. See Piping System Cleaning and Flushing Procedures later in this document. The flow rate is usually set between 2.25 gpm and 3 gpm per ton [2.9 l/m and 4.5 l/m per kW] of cooling capacity. Heat Controller recommends 2.5 gpm per ton

[3.2 l/m per kW] for most applications of water loop heat pumps. To insure proper maintenance and servicing, P/T ports are imperative for temperature and flow verification, as well as performance checks.

Cooling Tower/Boiler Systems typically utilize a common loop maintained 60-90°F [16-32°C]. The use of a closed circuit evaporative cooling tower with a secondary heat exchanger between the tower and the water loop is recommended. If an open type cooling tower is used continuously, chemical treatment and filtering will be necessary.

Low Water Temperature Cutout Setting - CXM2 or DXM2.5 Control: When an antifreeze is selected, the LT1 jumper (JW3) should be clipped to select the low temperature (Antifreeze 15°F [-9.4°C]) setpoint to avoid nuisance faults. See Figure 4: Low Water Temperature Cutout - LT1.

Figure 3: Typical Open Loop/Well Application

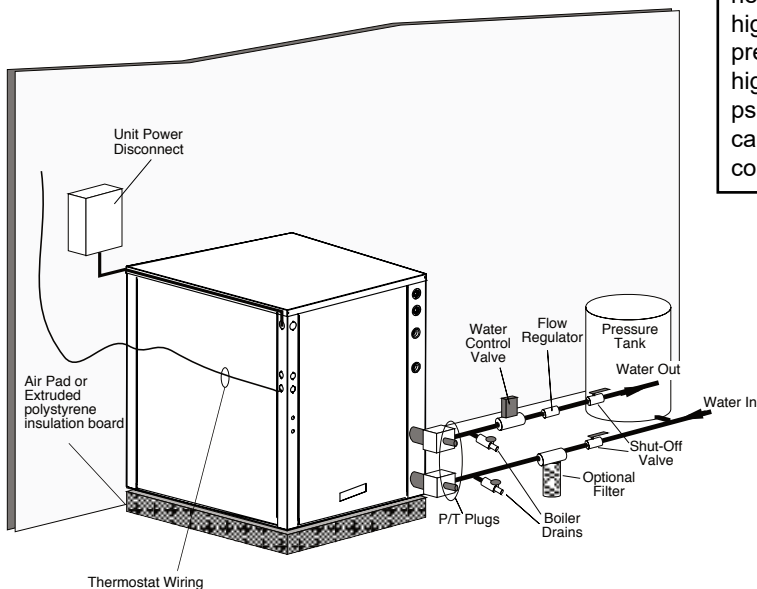

⚠ WARNING! ⚠

WARNING! Never jumper terminal "A" from CXM2 or DXM2.5 board #1 to CXM2 or DXM2.5 board #2 on multi-compressor/control board units. See Figure 5 in electrical section of this document for motorized valve wiring.

⚠ CAUTION! ⚠

CAUTION! Many units are installed with a factory or field supplied manual or electric shut-off valve. **DAMAGE WILL OCCUR** if shut-off valve is closed during unit operation. A high pressure switch must be installed on the heat pump side of any field provided shut-off valves and connected to the heat pump controls in series with the built-in refrigerant circuit high pressure switch to disable compressor operation if water pressure exceeds pressure switch setting. The field installed high pressure switch shall have a cut-out pressure of 300 psig and a cut-in pressure of 250 psig. This pressure switch can be ordered from Heat Controller with a 1/4" internal flare connection as part number 39B0005N02.

Ground-Water Heat Pump Applications

Typical open loop piping is shown in Figure 3. Shut off valves should be included in case of servicing. Boiler drains or other valves should be 'tee'd' into the line to allow acid flushing of just the heat exchanger. Pressure temperature plugs should be used so that flow and temperature can be measured. Supply and return water piping materials should be limited to copper, PE, or similar material. PVC or CPVC should never be used as they are incompatible with the POE oils used in HFC-410A products and piping system failure and property damage may result.

Water quantity should be plentiful and of good quality. Consult Table 1 for water quality guidelines. The unit can be ordered with either a copper or cupro-nickel water heat exchanger. Copper is recommended for closed loop systems and open loop ground water systems that are not high in mineral content or corrosiveness. In conditions anticipating heavy scale formation or in brackish water, a cupro-nickel heat exchanger is recommended.

In ground water situations where scaling could be heavy or where biological growth such as iron bacteria will be present, a closed loop system is recommended. It is recommended to install an intermediate heat exchanger to isolate an open loop from the heat pump loop on open well systems. Heat exchangers may over time lose heat exchange capabilities due to a build up of mineral deposits inside. These can be cleaned only by a qualified service mechanic as acid and special pumping equipment are required.

In areas with extremely hard water, the owner should be informed that the heat exchanger may require occasional acid flushing.

Expansion Tank and Pump - Use a closed, bladder-type expansion tank to minimize mineral formation due to air exposure. The expansion tank should be sized to handle at least one minute run time of the pump to prevent premature pump failure using its drawdown capacity rating. Discharge water from the unit is not contaminated in any manner and can be disposed of in various ways depending on local building codes; i.e. recharge well, storm sewer, drain field, adjacent stream or pond, etc. Most local codes forbid the use of sanitary sewer for disposal. Consult your local building and zoning department to assure compliance in your area.

WARNING!

WARNING! Polyolester Oil, commonly known as POE oil, is a synthetic oil used in many refrigeration systems including those with HFC-410A refrigerant. POE oil, if it ever comes in contact with PVC or CPVC piping, may cause failure of the PVC/CPVC. PVC/CPVC piping should never be used as supply or return water piping with water source heat pump products containing HFC-410A as system failures and property damage may result.

WARNING!

WARNING! Never jumper terminal "A" from CXM2 or DXM2.5 board #1 to CXM2 or DXM2.5 board #2 on multi-compressor/control bound units. See Figure 5 in electrical section of this document for motorized valve wiring.

Low Water Temperature Cut-Out Setting - For all open loop systems the 35°F [1.7°C] LT1 setting (factory setting-water) should be used to avoid freeze damage to the unit. See Figure 4: "Low Water Temperature Cutout - LT1".

Water Control Valve - Note the placement of the water control valve. Always maintain water pressure in the heat exchanger by placing water control valves at the outlet of the unit to prevent mineral precipitation. Pilot operated or Taco slow closing valve's solenoid valves are recommended to reduce water hammer. If water hammer persists, a mini-expansion tank can be mounted on the piping to help absorb the excess hammer shock. Insure that the total 'VA' draw of the valve can be supplied by the unit transformer. For instance the Taco slow closing valve can draw up to 35VA. This can overload smaller 40 or 50 VA transformers depending on the other controls employed. A typical pilot operated solenoid valve draws approximately 15VA.

Ground-Water Heat Pump Applications, Cont'd.

Flow Regulation - Flow regulation can be accomplished by two methods. First, most water control valves have a built in flow adjustment. By measuring the pressure drop through the unit heat exchanger, flow rate can be determined and compared to Tables 7 and 8. Since the pressure is constantly varying, two pressure gauges might be needed. Simply adjust the water control valve until the desired flow of 1.5 to 2 gpm per ton is achieved. Secondly, a flow control device may be installed. The devices are typically an orifice of plastic material that is designed to allow a specified flow rate. These are mounted on the outlet of the water control valve. On occasion, these valves can produce a velocity noise that can be reduced by applying some back pressure. This is accomplished by slightly closing the leaving isolation valve of the well water setup.

CAUTION!

CAUTION! Many units are installed with a factory or field supplied manual or electric shut-off valve. **DAMAGE WILL OCCUR** if shut-off valve is closed during unit operation. A high pressure switch must be installed on the heat pump side of any field provided shut-off valves and connected to the heat pump controls in series with the built-in refrigerant circuit high pressure switch to disable compressor operation if water pressure exceeds pressure switch setting. The field installed high pressure switch shall have a cut-out pressure of 300 psig and a cut-in pressure of 250 psig. This pressure switch can be ordered from Heat Controller with a 1/4" internal flare connection as part number 39B0005N02.

CAUTION!

CAUTION! Low temperature limit system will not allow leaving load water temperature (cooling mode) or leaving source water temperature (heating mode) to be below 42°F [5.6°C].

Ground-Loop Heat Pump Applications

⚠ CAUTION! ⚠

CAUTION! The following instructions represent industry accepted installation practices for Closed Loop Earth Coupled Heat Pump Systems. They are provided to assist the contractor in installing trouble free ground loops. These instructions are recommendations only. State and Local Codes **MUST** be followed and installation **MUST** conform to ALL applicable Codes. It is the responsibility of the Installing contractor to determine and comply with ALL applicable Codes and Regulations.

to leak in earth coupled applications and a flanged fitting substituted. P/T plugs should be used so that flow can be measured using the pressure drop of the unit heat exchanger in lieu of other flow measurement means. Earth loop temperatures can range between 25 to 110°F [-4 to 43°C], and 2.25 to 3 gpm of flow per ton [2.9 l/m to 3.9 l/m per kW] of cooling capacity is recommended in these applications. Upon completion of the ground loop piping, pressure test the loop to assure a leak free system. Horizontal Systems: Test individual loops as installed. Test entire system when all loops are assembled. Vertical U-Bends and Pond Loop Systems: Test Vertical U-bends and pond loop assemblies prior to installation with a test pressure of at least 100 psi [689 kPa].

Pre-Installation - Prior to installation, locate and mark all existing underground utilities, piping, etc. Install loops for new construction before sidewalks, patios, driveways, and other construction has begun. During construction, accurately mark all ground loop piping on the plot plan as an aid in avoiding potential future damage to the installation.

Flushing the Earth Loop - Upon completion of system installation and testing, flush the system to remove all foreign objects and purge to remove all air. Flush the loop first with the unit isolated to avoid flushing debris from the loop into the unit heat exchanger.

Piping Installation - All earth loop piping materials should be limited to only polyethylene fusion for inground sections of the loop. Galvanized or steel fitting should not be used at any time due to their tendency to corrode. All plastic to metal threaded fittings should be avoided due to their potential

Table 1: Antifreeze Percentages by Volume

Type	Minimum Temperature for Low Temperature Protection			
	10°F [-12.2°C]	15°F [-9.4°C]	20°F [-6.7°C]	25°F [-3.9°C]
Methanol	25%	21%	16%	10%
100% USP food grade Propylene Glycol	38%	25%	22%	15%
Ethanol*	29%	25%	20%	14%

* Must not be denatured with any petroleum based product

Antifreeze - In areas where minimum entering loop temperatures drop below 40°F [5°C] or where piping will be routed through areas subject to freezing, anti-freeze is needed. Alcohols and glycols are commonly used as antifreezes, however your local sales manager should be consulted for the antifreeze best suited to your area. Low temperature protection should be maintained to 15°F [9°C] below the lowest expected entering loop temperature. For example, if 30°F [-1°C] is the minimum expected entering loop temperature, the leaving loop temperature would be 25 to 22°F [-4 to -6°C] and low temperature protection should be at 15°F [-10°C] e.g. 30°F - 15°F = 15°F [-1°C - 9°C = -10°C]. All alcohols should be premixed and pumped from a reservoir outside of the

building when possible or introduced under water level to prevent fuming. Initially calculate the total volume of fluid in the piping system. Then use the percentage by volume shown in Table 2 for the amount of antifreeze. Antifreeze concentration should be checked from a well mixed sample using a hydrometer to measure specific gravity.

Low Water Temperature Cut-Out Setting -

CXM2 or DXM2.5 Control: When an antifreeze is selected, the LT1 jumper [JW3] should be clipped to select the low temperature (Antifreeze 15°F [-9.4°C]) setpoint to avoid nuisance faults. See Figure 4.

Ground-Loop Heat Pump Applications, Cont'd.

Water Control Valve - Note the placement of the water control valve. Always maintain water pressure in the heat exchanger by installing water control valves at the source out of the unit to prevent mineral precipitation. Position water high pressure switch between unit and valve. Pilot operated or slow closing valves are recommended to reduce water hammer. If water hammer persists, a mini-expansion tank can be mounted on the piping to help absorb the excess hammer shock. Insure that the total 'VA' draw of the valve can be supplied by the unit transformer. For instance, some slow closing valves can draw up to 35VA. This can overload smaller transformers depending on the other controls employed. A typical pilot operated solenoid valve draws approximately 15VA.

Flow Regulation - Install on source in of unit. Flow regulation can be accomplished by two methods. First, most water control valves have a built in flow adjustment. By measuring the pressure drop through the unit heat exchanger, flow rate can be determined and compared to Table 6. Since the pressure is constantly varying, two pressure gauges might be needed. Simply adjust the water control valve until the desired flow of 2.5 to 3 gpm per ton [2.0 to 2.6 l/m per kW] is achieved. Secondly, a flow control device may be installed. The devices are typically an orifice of plastic material that is designed to allow a specified flow rate. These are mounted on the outlet of the water control valve. On occasion, these valves can produce a velocity noise that can be reduced by applying some back pressure. This is accomplished by slightly closing the leaving isolation valve of the well water setup.

WARNING!

WARNING! Never jumper terminal "A" from CXM2 or DXM2.5 board #1 to CXM2 or DXM2.5 board #2 on multi-compressor/control bound units. See Figure 5 in electrical section of this document for motorized valve wiring.

CAUTION!

CAUTION! Many units are installed with a factory or field supplied manual or electric shut-off valve. **DAMAGE WILL OCCUR** if shut-off valve is closed during unit operation. A high pressure switch must be installed on the heat pump side of any field provided shut-off valves and connected to the heat pump controls in series with the built-in refrigerant circuit high pressure switch to disable compressor operation if water pressure exceeds pressure switch setting. The field installed high pressure switch shall have a cut-out pressure of 300 psig and a cut-in pressure of 250 psig. This pressure switch can be ordered from Heat Controller with a 1/4" internal flare connection as part number 39B0005N02.

Water Quality Standards

Table 2: Water Quality Standards

Clean water is essential to the performance and life span of water source heat pumps. Contaminants, chemicals, and minerals all have the potential to cause damage to the water heat heat exchanger if not treated properly. All closed water loop systems should undergo water quality testing and be maintained to the water quality standards listed in this table.

WATER QUALITY REQUIREMENTS							
For Closed-Loop and Open-Loop Systems							
	Description	Symbol	Units	Heat Exchanger Type			
				Closed Loop Recirculating	Open Loop, Tower, Ground Source Well		
				All Heat Exchanger Types	COAXIAL HX Copper Tube in Tube	COAXIAL HX Cupronickel	Brazed Plate HX 316 SS
Scaling Potential	pH - Chilled Water <85°F			7.0 to 9.0	7.0 to 9.0	7.0 to 9.0	7.0 to 9.0
	pH - Heated Water >85°F			8.0 to 10.0	8.0 to 10.0	8.0 to 10.0	8.0 to 10.0
	Alkalinity	(HCO ₃ ⁻)	ppm - CaCO ₃ equiv.	50 to 500	50 to 500	50 to 500	50 to 500
	Calcium	(Ca)	ppm	<100	<100	<100	<100
	Magnesium	(Mg)	ppm	<100	<100	<100	<100
	Total Hardness	(CaCO ₃)	ppm - CaCO ₃ equiv.	30 to 150	150 to 450	150 to 450	150 to 450
	Langelier Saturation Index	LSI		-0.5 to +0.5	-0.5 to +0.5	-0.5 to +0.5	-0.5 to +0.5
Ryznar Stability Index	RSI		6.5 to 8.0	6.5 to 8.0	6.5 to 8.0	6.5 to 8.0	
Corrosion Prevention	Total Dissolved Solids	(TDS)	ppm - CaCO ₃ equiv.	<1000	<1000	<1000	<1500
	Sulfate	(SO ₄ ²⁻)	ppm	<200	<200	<200	<200
	Nitrate	(NO ₃ ⁻)	ppm	<100	<100	<100	<100
	Chlorine (free)	(Cl)	ppm	<0.5	<0.5	<0.5	<0.5
	Chloride (water < 80°F)	(Cl ⁻)	ppm	<20	<20	<150	<150
	Chloride (water > 120°F)	(Cl ⁻)	ppm	<20	<20	<125	<125
	Hydrogen Sulfide ^a	(H ₂ S)	ppb	<0.5	<0.5	<0.5	<0.5
	Carbon Dioxide	(CO ₂)	ppm	0	<50	10 to 50	10 to 50
	Iron Oxide	(Fe)	ppm	<1.0	<1.0	<1.0	<0.2
	Manganese	(Mn)	ppm	< 0.4	<0.4	<0.4	<0.4
	Ammonia	(NH ₃)	ppm	<0.05	<0.1	<0.1	<0.1
	Chloramine	(NH ₂ CL)	ppm	0	0	0	0
Fouling & Biological	Iron Bacteria		cells/mL	0	0	0	0
	Slime Forming Bacteria		cells/mL	0	0	0	0
	Sulfate reducing bacteria		cells/mL	0	0	0	0
	Suspended Solids ^b	(TSS)	ppm	<10	<10	<10	<10
Electrolysis All HX types	Earth Ground Resistance ^x		Ohms	0	Consult NEC & local electrical codes for grounding requirements		
	Electrolysis Voltage ^δ		mV	<300	Measure voltage internal water loop to HP ground		
	Leakage Current ^δ		mA	<15	Measure current in water loop pipe		
	Building Primary Electrical Ground to unit, must meet local diameter and penetration length requirements Do not connect heat pump to steel pipe unless dissimilar materials are separated by using Di-electric unions. Galvanic corrosion of heat pump water pipe will occur.						

Water Quality Standards, Cont'd.

1. The Heat Controller Water Quality Table provides water quality requirements for coaxial & brazed plate heat exchangers.
 2. The water must be evaluated by an independent testing facility comparing site samples against this Table. When water properties are outside of these parameters, the water must either be treated by a professional water treatment specialist to bring the water quality within the boundaries of this specification, or an external secondary heat exchanger must be used to isolate the heat pump water system from the unsuitable water. Failure to do so will void the warranty of the heat pump system and will limit liability for damage caused by leaks or system failure.
 3. Regular sampling, testing and treatment of the water is necessary to assure that the water quality remains within acceptable levels thereby allowing the heat pump to operate at optimum levels.
 4. If closed-loop systems are turned off for extended periods, water samples must be tested prior to operating the system.
 5. For optimal performance, it is recommended that the closed-loop piping systems are initially filled with de-ionized water.
 6. Well water with chemistry outside of these boundaries, and salt water or brackish water requires an external secondary heat exchanger. Surface/Pond water should not be used.
 7. If water temperature is expected to fall below 40°F, antifreeze is required. Refer to the heat pump IOM for the correct solution ratios to prevent freezing.
- α Hydrogen Sulfide has an odor of rotten eggs. If one detects this smell, a test for H₂S must be performed. If H₂S is detected above the limit indicated, remediation is necessary (Consult with your Water Testing/Treatment Professional) or a secondary heat exchanger is required using appropriate materials as recommended by the heat exchanger supplier.
 - β Suspended solids and particulates must be filtered to prevent fouling and failure of heat exchangers. Strainers or particulate filters must be installed to provide a maximum particle size of 600 micron (0.60 mm, 0.023 in.) using a 20 to 30 mesh screen size. When a loop is installed in areas with fine material such as sand or clay, further filtration is required to a maximum of 100 micron. Refer to the Strainer / Filter Sizing Chart to capture the particle sizes encountered on the site.
 - χ An electrical grounding system using a dedicated ground rod meeting NEC and Local Electrical codes must be installed. Building Ground must not be connected the WSHP piping system or other plumbing pipes.
 - δ Refer to IOM for instructions on measuring resistance and leakage currents within water loops.

Do not use PVC pipe for water loop (compressor POE oil and glycols damage PVC) use of HDPE pipe is recommended.

Strainer / Filter Sizing			
Mesh Size	Particle Size		
	Microns	MM	Inch
20	840	0.840	0.0340
30	533	0.533	0.0210
60	250	0.250	0.0100
100	149	0.149	0.0060
150	100	0.100	0.0040
200	74	0.074	0.0029

ppm = parts per million
ppb = parts per billion

Water Quality Standards, Cont'd.

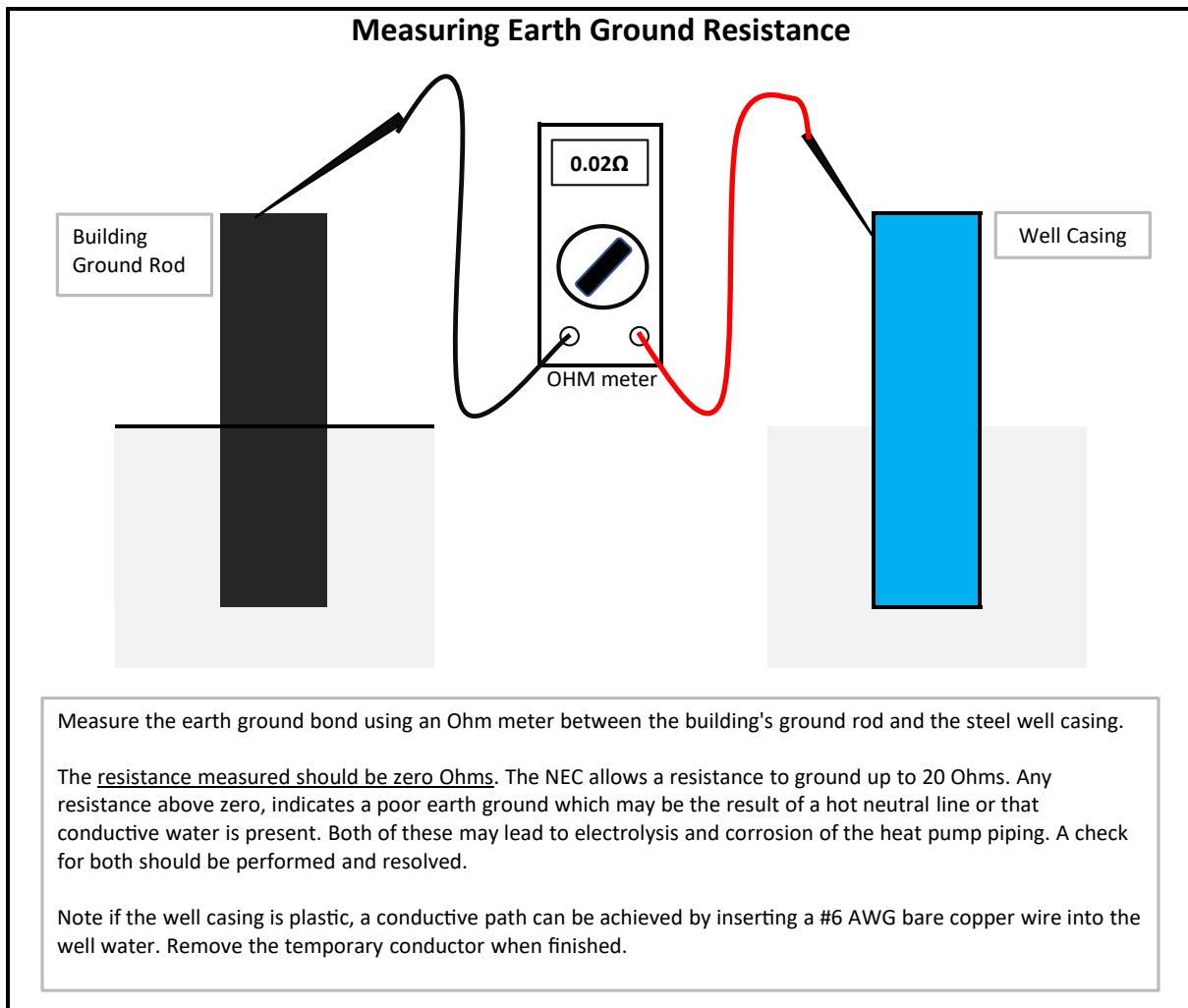

Water Quality Standards, Cont'd.

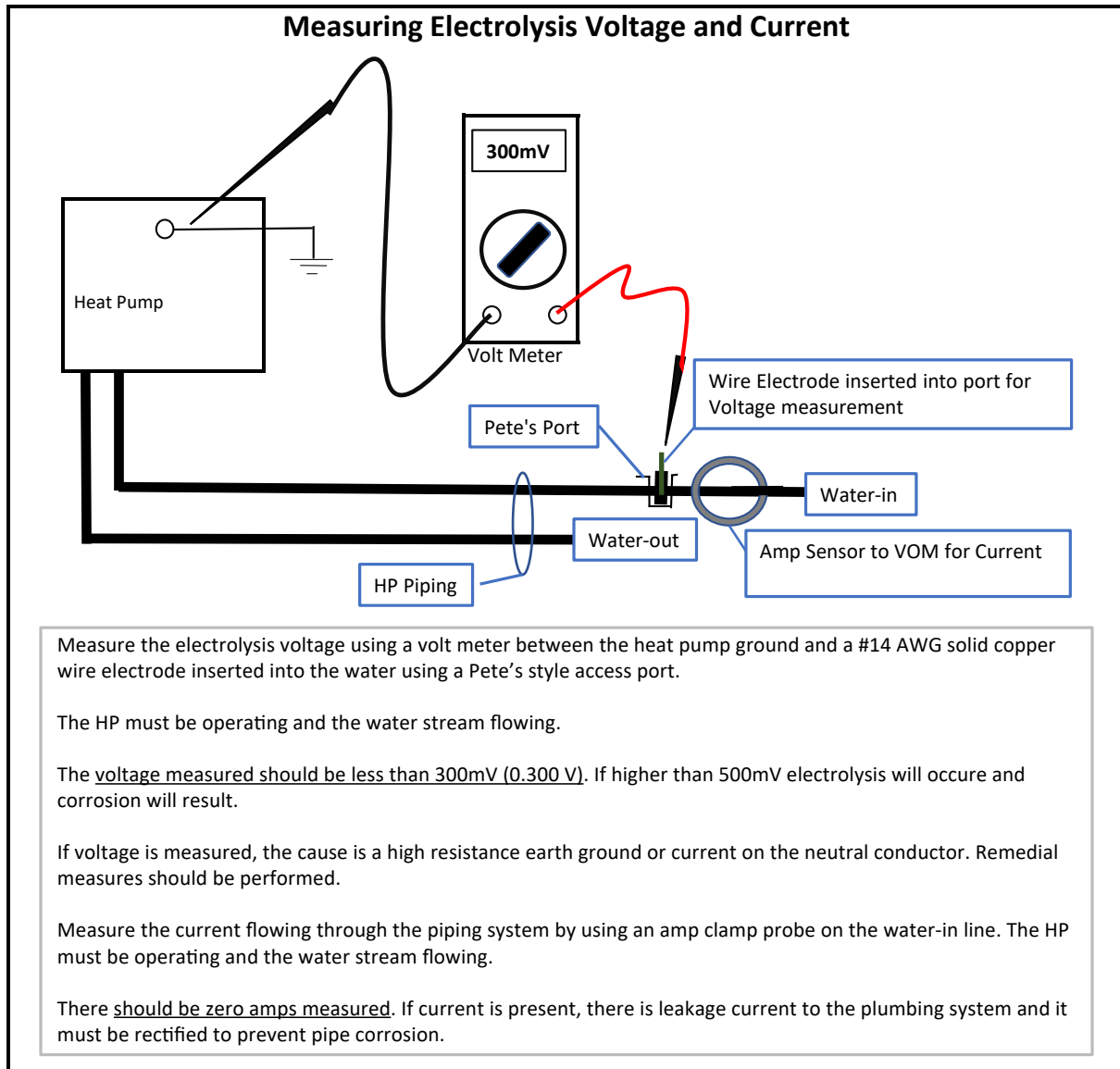

Electrical – Line Voltage

⚠ CAUTION! ⚠

CAUTION! Use only copper conductors for field installed electrical wiring. Unit terminals are not designed to accept other types of conductors.

General Line Voltage Wiring - Be sure the available power is the same voltage and phase as that shown on the unit serial plate. Line and low voltage wiring must be done in accordance with local codes or the National Electric Code, whichever is applicable.

HWW Power Connection - Line voltage connection is made by connecting the incoming line voltage wires to L1, L2, and L3 on power distribution block. Consult electrical data table for correct fuse size.

208 Volt Operation - All 208-230 Volt units are factory wired for 208 Volt. The transformers may be switched to 230V operation as illustrated on the wiring diagram by switching the Red (208V) and the Orange (230V) at the contactor terminal L2.

⚠ WARNING! ⚠

WARNING! Disconnect electrical power source to prevent injury or death from electrical shock.

⚠ WARNING! ⚠

WARNING! To avoid possible injury or death due to electrical shock, open the power supply disconnect switch and secure it in an open position during installation.

All field installed wiring, including electrical ground, must comply with the National Electrical Code as well as all applicable local codes.

Refer to the unit wiring diagrams for fuse sizes and a schematic of the field connections which must be made by the installing (or electrical) contractor.

Consult the unit wiring diagram located on the inside of the compressor access panel to ensure proper electrical hookup. All final electrical connections must be made with a length of flexible conduit to minimize vibration and sound transmission to the building.

HWW Electrical Data

Model	Voltage Code	Voltage	Voltage Min/Max	Compressor			Total Unit FLA	Min Circuit Amps	SCCR rms Symetrical	SCCR Volts Maximum	Max Fuse/HACR
				Qty	RLA	LRA					
HWW036	G	208-230/60/1	187/254	1	16.7	79	16.7	20.8	5	600	35
	E	265/60/1	239/292	1	13.5	72	13.5	16.8	5	600	30
	H	208-230/60/3	187/254	1	10.4	73	10.4	13.1	5	600	20
	F	460/60/3	414/506	1	5.8	38	5.8	7.2	5	600	15
	N	575/60/3	518/633	1	3.8	36.5	3.8	4.7	5	600	15
HWW060	G	208-230/60/1	187/254	1	26.3	134	26.3	32.9	5	600	50
	H	208-230/60/3	187/254	1	15.6	110	15.6	19.5	5	600	35
	F	460/60/3	414/506	1	7.8	52	7.8	9.8	5	600	15
HWW120	G	208-230/60/1	187/254	2	26.3	134	52.6	59.2	5	600	80
	H	208-230/60/3	187/254	2	15.6	110	31.2	35.1	5	600	50
	F	460/60/3	414/506	2	7.8	52	15.6	17.6	5	600	25

Electrical – Low Voltage

Figure 4: Changing LT1-Low Water Temperature Cutout Setpoint

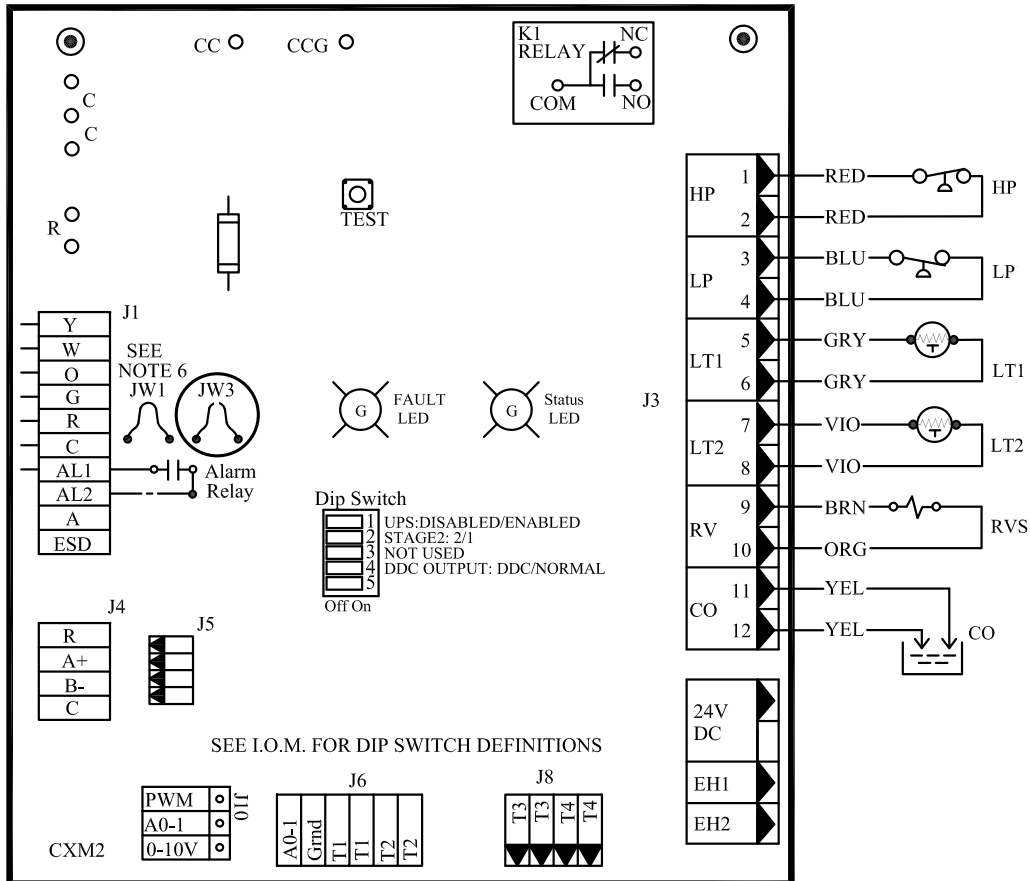

Thermostat Connections - The aquastat/thermostat should be wired directly to the CXM2/DXM2.5 board #1. Note: The HWW second stage is wired directly to the CXM2 #2.

Low Water Temperature Cutout - LT1 - The CXM2/DXM2.5 control allows the field selection of source fluid low temperature cutout points. The factory setting of LT1 is set for water (35°F [1.7°C]). In cold temperature applications jumper JW3 (LT1- antifreeze 15°F [-9.4°C]) should be clipped as shown in Figure 4 to change the setting to 10°F [-12.2°C], a more suitable temperature when using antifreezes. Never clip JW3 prior to antifreeze being added to the loop.

Electrical – Accessories

Accessory Connections - A terminal paralleling the compressor contactor coil has been provided on the CXM2/DXM2.5 control of the HWW line. "A" has been provided to control accessory devices, such as water valves, electronic air cleaners, humidifiers, etc. Note: This terminal must be used only with 24 Volt signals and not line voltage signals. This signal operates with the compressor contactor. See Figure 8 or the wiring schematic for details.

24 Volt Accessory Wiring CXM2/DXM2.5 Terminal Strip

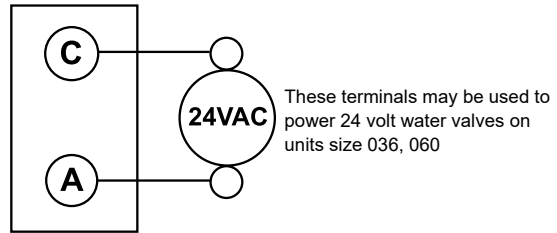

! WARNING! !

WARNING! Never jumper terminal "A" from CXM2 or DXM2.5 board #1 to CXM2 or DXM2.5 board #2 on multi-compressor/control bound units. See Figure 5 in electrical section of this document for motorized valve wiring.

Figure 5: Field Wiring of 24 Volt Motorized Valve for Units Size 120-340

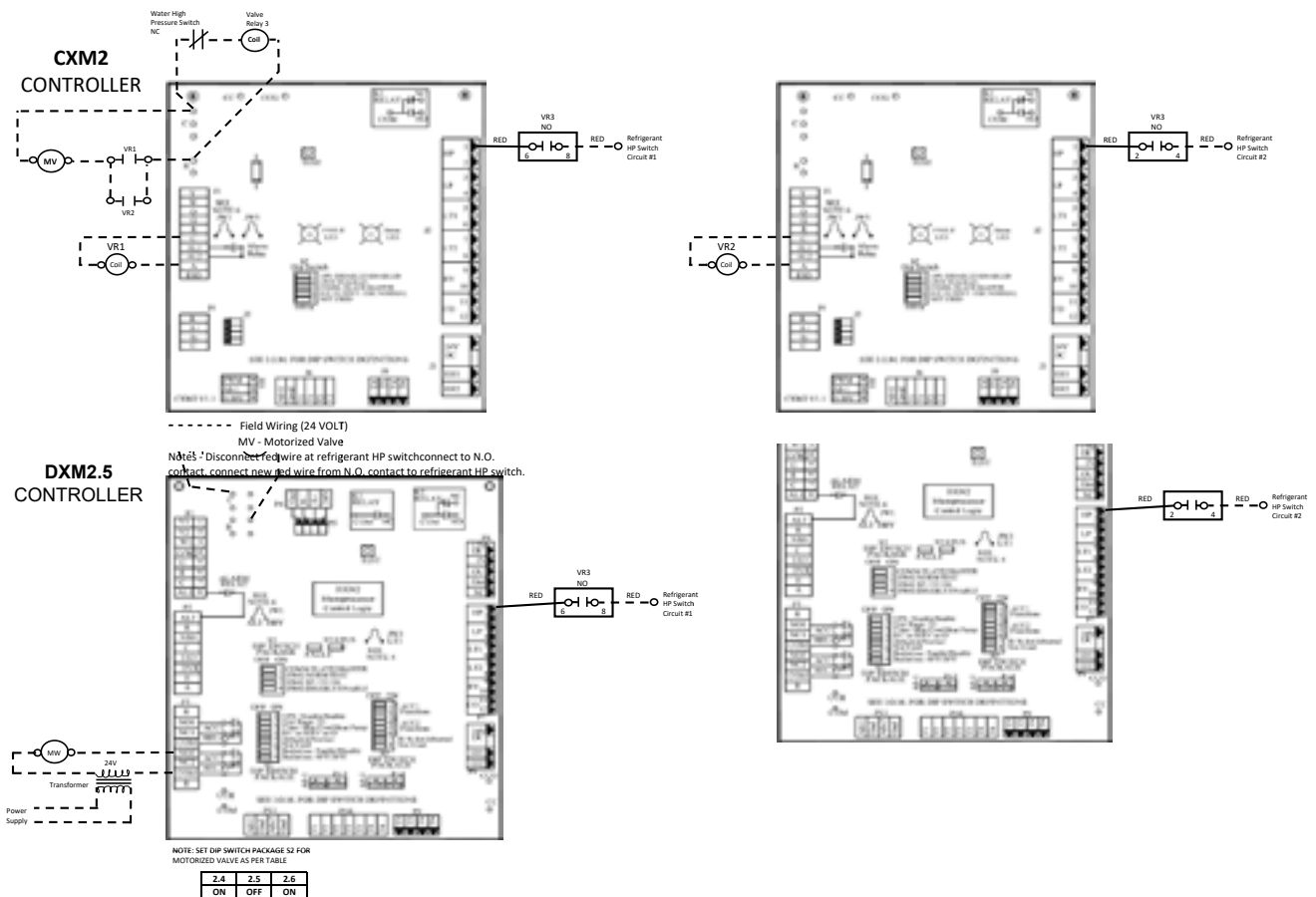

CXM2/DXM2.5, OR MPC CONTROL OPERATION

Note: See CXM2 AOM (part #97B0003N12), DXM2.5 AOM (part #97B0003N13), or MPC Controller AOM (part #97B0031N01) on the web at <https://files.hvac-wiringdiagrams.com/MARS/marswire.html>

Electrical – Line Voltage

All field installed wiring, including electrical ground, must comply with the National Electrical Code as well as all applicable local codes.

Refer to the unit wiring diagrams for fuse sizes and a schematic of the field connections which must be made by the installing (or electrical) contractor.

Consult the unit wiring diagram located on the inside of the compressor access panel to ensure proper electrical hookup.

All final electrical connections must be made with a length of flexible conduit to minimize vibration and sound transmission to the building.

208 Volt Operation - All 208-230 Volt units are factory wired for 208 Volt. The transformers may be switched to 230V operation as illustrated on the wiring diagram. By switching the Red (230V) and the Orange (208V) at the contactor terminal L2.

HWW036-060 Series Line Voltage Field Wiring Commercial Class (3 phase shown)

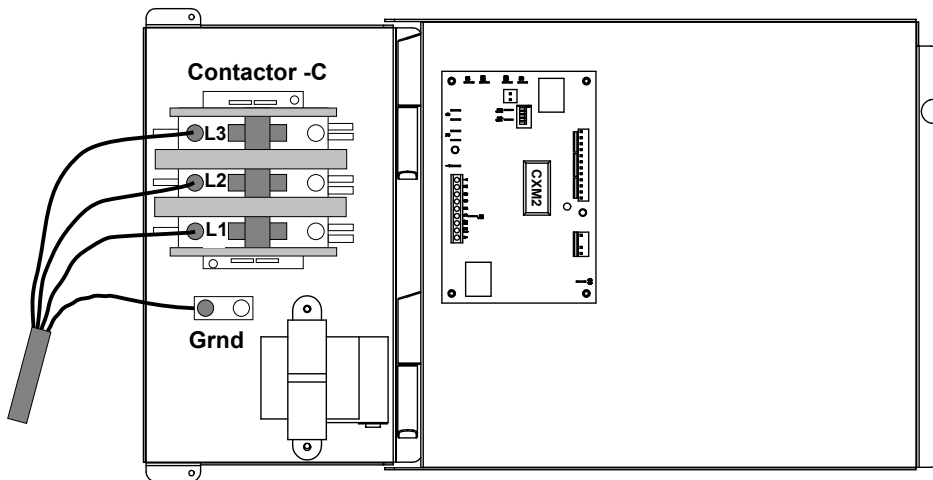

HWW120 Series Line Voltage Field Wiring Commercial Class

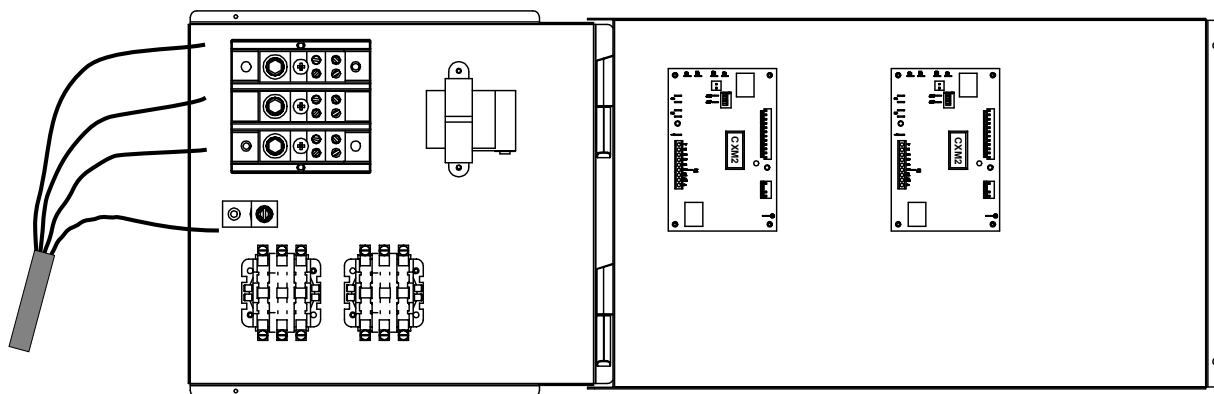

Electrical – Low Voltage

Thermostat Connections - The aquastat/thermostat should be wired directly to the CXM2/DXM2.5 board as shown in Figure 6a for HWW036-060 and Figure 6b for the HWW120. Note the HWW second stage is wired directly to the CXM2 #2.

Figure 6a. HWW036-060 Low Voltage Field Wiring (CXM2 shown)

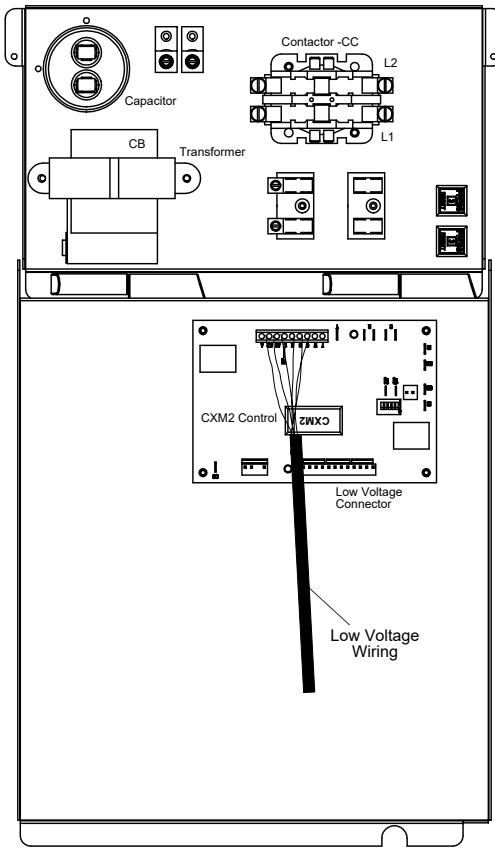
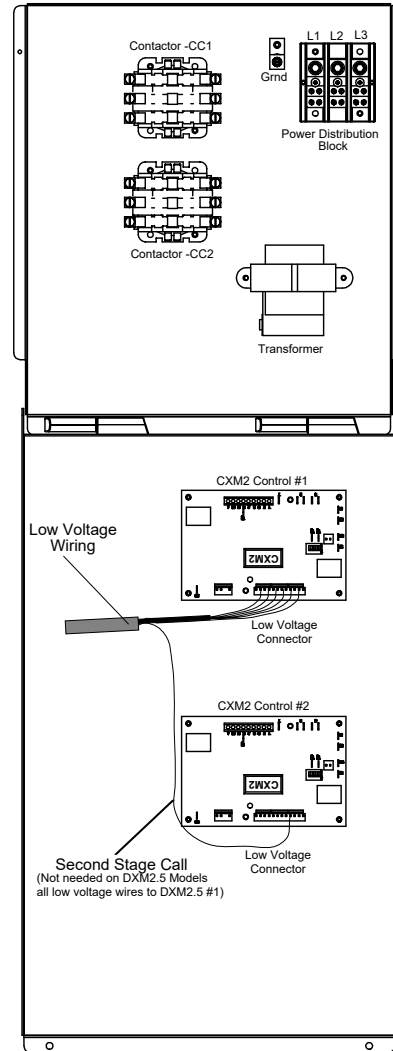
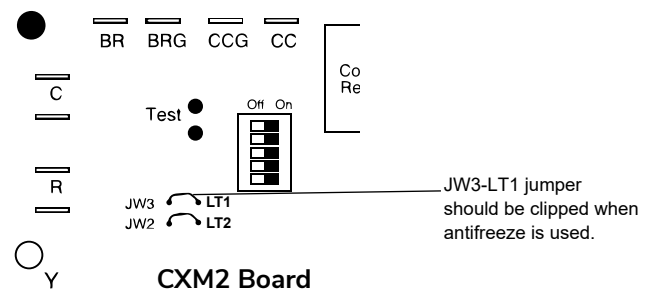

Figure 6b: HWW120 Low Voltage Field Wiring (CXM2 shown)



Low Water Temperature Cutout - LT1 - The CXM2/DXM2.5 control allows the field selection of source fluid low temperature cutout points. The factory setting of LT1 is set for water (30°F). In cold temperature applications jumper JW3 (LT1- antifreeze 10°F) should be clipped as shown in Figure 7 to change the setting to 10°F, a more suitable temperature when using antifreezes. It should be noted that the extended range option should be specified to operate the HWW Series at entering water temperatures below 60°F.

Figure 7: Changing LT1-Low Water Temperature Cutout Setpoint



HWW Series Wiring Diagram Matrix

Diagrams can be located on-line at <https://files.hvac-wiringdiagrams.com/MARS/marswire.html> using the part numbers presented below.

Unit Controller	Voltage	Size	
		036-060	120
CXM2	208-230/60/1, 265/60/1	96B0401N52	96B0401N58
	208-230/60/3, 460/60/3, 575/60/3	96B0401N53	96B0401N59
AUX WD CXM2 w/MPC	All	96B0146N14	96B0146N16
DXM2.5	208-230/60/1, 265/60/1	96B0402N38	96B0402N41
	208-230/60/3, 460/60/3, 575/60/3	96B0402N39	96B0402N42
AUX WD DXM2 w/MPC	All	96B0146N14	96B0146N16

Cleaning and flushing of the WLHP piping system is the single most important step to ensure proper start-up and continued efficient operation of the system.

Follow the instructions below to properly clean and flush the system:

1. Verify electrical power to the unit is disconnected.
2. Install the system with the supply hose connected directly to the return riser valve. Use a single length of flexible hose.
3. Open all air vents. Fill the system with the water. DO NOT allow system to overflow. Bleed all air from the system. Pressurize and check the system for leaks and repair appropriately.
4. Verify all strainers are in place. Start the pumps, and systematically check each vent to ensure all air is bled from the system.
5. Verify make-up water is available. Adjust make-up water appropriately to replace the air which was bled from the system. Check and adjust the water/air level in the expansion tank.
6. Set the boiler to raise the loop temperature to approximately 85°F [29°C]. Open the a drain at the lowest point in the system. Adjust the make-up water replacement rate to equal the rate of bleed.
7. Refill the system and add trisodium phosphate in a proportion of approximately one pound per 150 gallons [1/2 kg per 750 L] of water (or other equivalent approved cleaning agent). Reset the boiler to raise the loop temperature to about 100°F [38°C]. Circulate the solution for a minimum of 8 to 24 hours. At the end of this period, shut off the circulating pump and drain the solution. Repeat system cleaning if desired.

Piping System Cleaning & Flushing

CAUTION!

CAUTION! To avoid possible damage to a plastic (PVC) piping system, do not allow temperatures to exceed 110°F [43°C].

8. When the cleaning process is complete, remove the short-circuited hoses. Reconnect the hoses to the proper supply, and return connections to each of the units. Refill the system and bleed off all air.
9. Test the system pH with litmus paper. The system water should be slightly alkaline (pH 7.5-8.5). Add chemicals, as appropriate, to maintain acidity levels.
10. When the system is successfully cleaned, flushed, refilled and bled, check the main system panels, safety cutouts and alarms. Set the controls to properly maintain loop temperatures.

CAUTION!

CAUTION! DO NOT use 'stop leak' or any similar chemical agent in this system. Addition of these chemicals to the loop water will foul the system and inhibit unit operation.

Controls – CXM2 and DXM2.5



CXM2 Controls

For detailed controller information, see the CXM2 Application, Operation, and Maintenance (AOM) manual (part # 97B0137N01). To confirm the controller type of your particular unit, refer to digit 9 on the unit model number and the unit nomenclature diagram found on page 3 of this manual.



DXM2.5 Controls

For detailed controller information, see the DXM2.5 Application, Operation, and Maintenance (AOM) manual (part # 97B0142N01). To confirm the controller type of your particular unit, refer to digit 9 on the unit model number and the unit nomenclature diagram found on page 3 of this manual.

Unit & System Checkout

! WARNING! !

WARNING! Verify ALL water controls are open and allow water flow prior to engaging the compressor. Freezing of the coax or water lines can permanently damage the heat pump.

Note: The manufacturer strongly recommends all piping connections, both internal and external to the unit, be pressure tested by an appropriate method prior to any finishing of the interior space or before access to all connections is limited. Test pressure may not exceed the maximum allowable pressure for the unit and all components within the water system. The manufacturer will not be responsible or liable for damages from water leaks due to inadequate or lack of a pressurized leak test, or damages caused by exceeding the maximum pressure rating during installation.

! WARNING! !

WARNING! Polyolester Oil, commonly known as POE oil, is a synthetic oil used in many refrigeration systems including those with HFC-410A refrigerant. POE oil, if it ever comes in contact with PVC or CPVC piping, may cause failure of the PVC/CPVC. PVC/CPVC piping should never be used as supply or return water piping with water source heat pump products containing HFC-410A as system failures and property damage may result.

BEFORE POWERING SYSTEM, please check the following:

UNIT CHECKOUT

- Balancing/Shutoff Valves: Ensure all isolation valves are open, water control valves wired and open or coax may freeze and burst.
- Line Voltage and Wiring: Ensure Voltage is within an acceptable range for the unit and wiring and fuses/breakers are properly sized. Low voltage wiring is complete.
- Unit Control Transformer: Ensure transformer has properly selected control voltage tap. 208-230V units are factory wired for 208V operation unless specified otherwise.
- Entering Water: Ensure entering water temperatures are within operating limits of Table 6.
- Low Water Temperature Cutout: Verify low water temperature cut-out on CXM2/DXM2.5 is properly set.
- Water Flow Balancing: Verify inlet and outlet water temperatures on both Load and source are recorded for each heat pump upon startup. This check can eliminate nuisance trip outs and high velocity water flows that can erode heat exchangers.
- Unit Controls: Verify CXM2 or DXM2.5 field selection options are proper and complete.

SYSTEM CHECKOUT

- System Water Temperature: Check load and source water temperature for proper range and also verify heating and cooling setpoints for proper operation.
- System pH: System water pH is 6 - 8.5. Proper pH promotes longevity of hoses and fittings.
- System Flushing: Verify all hoses are connected end to end when flushing to ensure debris bypasses unit heat exchanger and water valves etc. Water used in the system must be potable quality initially and clean of dirt, piping slag, and strong chemical cleaning agents. Verify all air is purged from the system. Air in the system can cause poor operation or system corrosion.
- Cooling Tower/Boiler: Check equipment for proper setpoints and operation.
- Standby Pumps: Verify the standby pump is properly installed and in operating condition.
- System Controls: Verify system controls function and operate in the proper sequence.
- Low Water Temperature Cutout: Verify low water temperature cut-out controls are provided for the outdoor portion of the loop or operating problems will occur.
- System Control Center: Verify control center and alarm panel for proper setpoints and operation.
- Strainers: Verify 20 mesh (841 micron) [0.84mm] strainers are installed in load and source water piping. Confirm maintenance schedule for strainers.
- Miscellaneous: Note any questionable aspects of the installation.

! WARNING! !

WARNING! To avoid equipment damage, DO NOT leave system filled in a building without heat during the winter unless antifreeze is added to system water. Condenser coils never fully drain by themselves and will freeze unless winterized with antifreeze.

Figure 5: Test Mode Button

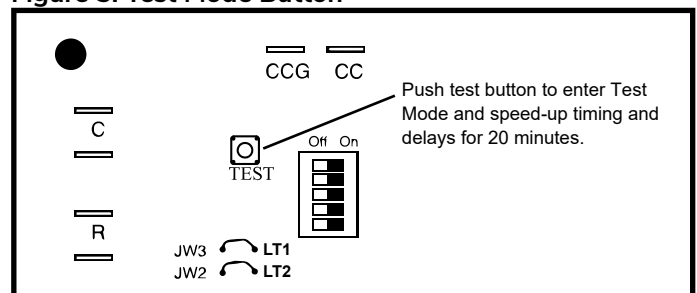

CXM2 BOARD

Unit Start-Up Procedure

WARNING!

WARNING! When the disconnect switch is closed, high voltage is present in some areas of the electrical panel. Exercise caution when working with energized equipment.

1. Adjust all valves to their full open position. Turn on the line power to all heat pump units.
2. Operate each unit in the cooling cycle. Loop water temperature entering the heat pumps should be between 70°F [21°C] and 110° F [43°C].
3. Operate each heat pump in the heating cycle immediately after checking cooling cycle operation. A time delay will prevent the compressor from re-starting for approximately five (5) minutes.
4. Establish a permanent operating record by logging the unit operating conditions at initial start-up for each unit.
5. If a unit fails to operate, conduct the following checks:
 - a. Check the voltage and current. They should comply with the electrical specifications described on the unit nameplate.
 - b. Look for wiring errors. Check for loose terminal screws where wire connections have been made on both the line and low-voltage terminal boards.
 - c. Check the supply and return piping. They must be properly connected to the inlet and outlet connections on the unit.
 - d. If the checks described above fail to reveal the problem and the unit still will not operate, contact a trained service technician to ensure proper diagnosis and repair of the equipment.

Note: Units have a five minute time delay in the control circuit that can be eliminated on the CXM2 PCB as shown in Figure 5. See controls description for detailed features of the control.

WARNING!

WARNING! Verify ALL water controls are open and allow water flow prior to engaging the compressor. Freezing of the coax or water lines can permanently damage the heat pump.

Table 6: Water Temperature Change Through Source Heat Exchanger

Water Flow, gpm [l/m]	Rise, Cooling °F, [°C]	Drop, Heating °F, [°C]
For Closed Loop: Ground Source or Closed Loop Systems at 3 gpm per ton [3.9 l/m per kW]	9 - 12 [5 - 6.7]	4 - 8 [2.2 - 4.4]
For Open Loop: Ground Water Systems at 1.5 gpm per ton [2.0 l/m per kW]	20 - 26 [11.1 - 14.4]	10 - 17 [5.6 - 9.4]

Table 7: Coax Water Pressure Drop HWW036-120

Model	GPM	Pressure Drop PSI			
		30°F	50°F	70°F	90°F
Source/Outdoor Coax					
036	4.5	1.7	1.3	1.0	0.8
	6.8	4.1	3.4	2.8	2.4
	9.0	7.1	6.0	5.1	4.5
060	7.5	1.5	1.3	1.1	0.9
	11.3	4.0	3.4	3.0	2.7
	15.0	6.9	6.2	5.5	5.0
120	15.0	1.7	1.4	1.2	0.9
	22.5	4.4	3.8	3.3	2.7
	30.0	7.6	6.8	6.1	5.0
Load/Outdoor Coax					
036	4.5		0.6	0.5	0.3
	6.8		1.4	1.3	1.1
	9.0		2.6	2.4	2.2
060	7.5		1.4	1.3	1.2
	11.3		3.5	3.2	3.0
	15.0		6.2	5.8	5.5
120	15.0		1.6	1.4	1.3
	22.5		3.8	3.5	3.3
	30.0		6.8	6.4	6.0

Must use antifreeze if operation falls in grey area

Operation not recommended

Multiply PSI x 2.31 to determine ft of hd

Operating Pressures

036-120 (120 Per Circuit)									
Source Entering Water Temp °F	Source Water Flow GPM/ton	Cooling						Water Temp Rise °F Source	Water Temp Drop °F Load
		Load EWT F @ 1.5-3.0 GPM/Ton	Suction Pressure PSIG	Discharge Pressure PSIG	Super-heat	Sub-cooling			
50	1.5	50	99-106	230-234	11-18	18-25	20-28	7-15	
		60	111-122	241-243	11-18	18-25		8-17	
		70	122-137	251-253	17-25	18-25		8-19	
		80	126-145	254-258	26-35	18-25		9-20	
	2.3	50	98-105	212-214	18-23	14-20	13-18	7-15	
		60	106-117	218-220	18-23	14-20		8-17	
		70	114-129	225-227	24-32	14-20		9-19	
		80	117-135	228-230	32-41	14-20		9-20	
	3.0	50	87-101	199-203	12-18	12-18	9-12	8-16	
		60	91-113	203-207	12-18	12-18		8-17	
		70	95-124	204-216	16-34	12-18		9-19	
		80	107-128	212-217	33-35	12-18		9-20	
80	1.5	50	104-111	343-348	9-14	18-25	19-28	7-14	
		60	121-132	355-360	9-14	18-25		7-16	
		70	138-152	367-373	9-14	18-25		8-18	
		80	148-161	377-381	12-23	18-25		9-20	
	2.3	50	103-111	320-325	8-14	14-21	13-18	7-14	
		60	118-129	328-334	8-14	14-21		8-16	
		70	132-147	336-344	12-20	14-21		8-18	
		80	140-172	343-353	19-29	14-21		9-20	
	3.0	50	94-110	305-314	9-13	12-18	8-12	7-15	
		60	112-121	313-319	9-13	12-18		8-16	
		70	121-146	317-329	12-20	12-18		9-18	
		80	131-151	324-333	18-27	12-18		9-20	
110	1.5	50	109-116	483-497	9-13	17-23	18-26	5-11	
		60	128-135	494-511	9-13	17-23		6-13	
		70	147-154	505-525	9-13	17-23		7-15	
	2.3	50	109-116	459-473	9-13	15-20	14-17	5-11	
		60	127-135	466-484	9-13	15-20		6-13	
		70	153-159	473-495	9-13	15-20		7-15	
	3.0	50	100-112	444-431	9-14	12-17	8-13	5-12	
		60	120-130	449-467	9-14	12-17		6-14	
		70	131-152	454-474	9-14	12-17		7-15	
		80	153-164	463-479	13-21	12-17		8-17	

Operating Pressures, Cont'd.

036-120 (120 Per Circuit)								
Source Entering Water Temp °F	Source Water Flow GPM/ton	Heating					Water Temp Drop °F Source	Water Temp Rise °F Load
		Load EWT F @ 1.5-3.0 GPM/Ton	Suction Pressure PSIG	Discharge Pressure PSIG	Super-heat	Sub-cooling		
20	3.0	60	56-63	199-228	4-14	6-14	2-6	5-14
		80	58-65	286-297	4-14	6-14		5-14
		90	59-66	310-344	4-14	6-14		4-14
		100	61-65	360-385	4-14	6-14		4-14
		120	64-69	459-510	4-14	6-14		4-13
50	1.5	60	85-95	212-224	6-11	7-11	9-16	6-17
		80	91-99	290-310	6-11	7-11		6-17
		90	92-101	326-338	6-11	7-11		6-17
		100	96-103	381-399	6-11	7-11		5-17
		120	100-108	474-488	6-11	7-11		4-16
	2.3	60	95-102	215-228	6-13	7-11	6-12	7-18
		80	98-106	299-313	6-13	7-11		6-18
		90	99-108	329-341	6-13	7-11		6-18
		100	102-110	384-401	6-13	7-11		6-17
		120	106-114	475-491	6-13	7-11		5-17
	3.0	60	95-107	215-256	6-14	7-15	5-9	7-19
		80	101-110	310-326	6-14	7-15		7-19
		90	103-112	329-376	6-14	7-15		6-19
		100	105-114	399-414	6-14	7-15		6-18
		120	108-118	476-524	6-14	7-15		5-17
80	1.5	60	109-129	225-237	14-26	5-14	15-21	8-18
		80	123-138	314-327	14-26	5-14		8-19
		90	130-142	343-357	10-15	5-14		7-19
		100	137-147	402-415	10-15	5-14		7-19
		120	150-157	493-504	10-15	5-14		6-20
	2.3	60	111-132	227-239	14-38	6-15	10-15	8-20
		80	135-147	315-330	14-38	6-15		8-20
		90	143-152	344-360	10-16	6-15		8-20
		100	145-154	405-418	10-16	6-15		7-20
		120	156-163	494-507	10-16	6-15		6-20
	3.0	60	110-149	227-279	19-44	6-18	7-12	9-21
		80	135-150	286-332	19-44	6-18		8-21
		90	145-166	345-408	13-23	6-18		8-21
		100	148-158	405-420	13-23	6-18		8-21

Preventive Maintenance

Heat Exchanger Maintenance -

(Direct Ground Water Applications Only)

If the installation is performed in an area with a known high mineral content (125 P.P.M. or greater) in the water, it is best to establish with the owner a periodic maintenance schedule so the coil can be checked regularly. Consult the well water applications section of this manual for a more detailed water coil material selection. Should periodic coil cleaning be necessary, use standard coil cleaning procedures which are compatible with either the heat exchanger material or copper water lines. Generally, the more water flowing through the unit the less chance for scaling therefore 2.5 gpm per ton [2.0 l/m per kW] is recommended as a minimum flow.

Heat Exchanger Maintenance -

(All Other Water Loop Applications)

Generally water coil maintenance is not needed however, if the installation is located in a system with a known high dirt or debris content, it is best to establish with the owner a periodic maintenance schedule so the coil can be checked regularly. These dirty installations are a result of the deterioration of iron or galvanized piping or components in the system or open cooling towers requiring heavy chemical treatment and mineral buildup through water use. Should periodic coil cleaning be necessary, use standard coil cleaning procedures which are compatible with both the heat exchanger material and copper water lines. Generally, the more water flowing through the unit, the less chance for scaling, however flow rates over 3 gpm per ton [3.9 l/m per kW] can produce water (or debris) velocities that can erode the heat exchanger wall and ultimately produce leaks.

Clean or replace 20 mesh (841 micron) [0.84mm] strainer/filters on a timely schedule.

Compressors - Conduct annual amperage checks to ensure amp draw is no more than 10% greater than that indicated by serial plate data.

Cabinet - Do not allow water to stay in contact with the cabinet for long periods of time to prevent corrosion of the cabinet sheet metal. Generally vertical cabinets are set up from the floor a few inches for prevention. The cabinet can be cleaned using a mild detergent.

Refrigerant System - To maintain sealed circuit integrity, do not install service gauges unless unit operation appears abnormal. Reference the operating chart for pressure and temperatures. Verify that air and water flow rates are at proper levels before servicing the refrigerant circuit.

If the refrigerant circuit is opened for any reason, a new liquid line filter-drier must be installed.

Start-Up Log Sheet

Installer: Complete unit and system checkout and follow unit start-up procedures in the IOM. Use this form to record unit information, temperatures and pressures during start-up. Keep this form for future reference.

Job Name: _____ **Street Address:** _____

Model Number: _____ **Serial Number:** _____

Unit Location in Building: _____

Date: _____ **Sales Order No:** _____

In order to minimize troubleshooting and costly system failures, complete the following checks and data entries before the system is put into full operation.

Temperatures: F or C

Antifreeze: _____%

Type of Antifreeze: _____

		Cooling Mode	Heating Mode
Source	Entering Fluid Temperature		
	Leaving Fluid Temperature		
	Temperature Differential		
	Pressure In		
	Pressure Out		
	Pressure Differential		
Load	Entering Fluid Temperature		
	Leaving Fluid Temperature		
	Temperature Differential		
	Pressure In		
	Pressure Out		
	Pressure Differential		
Compressor	Amps		
	Volts		
	Discharge Line Temperature (6" from Compressor Outlet)		

Allow unit to run 15 minutes in each mode before taking data.

Do not connect gauge lines

Refrigeration Troubleshooting Form

Water-to-Water Units

Customer: _____ Loop Type: _____ Startup Date: _____
 Model #: _____ Serial #: _____ Antifreeze Type & %: _____
 Complaint: _____

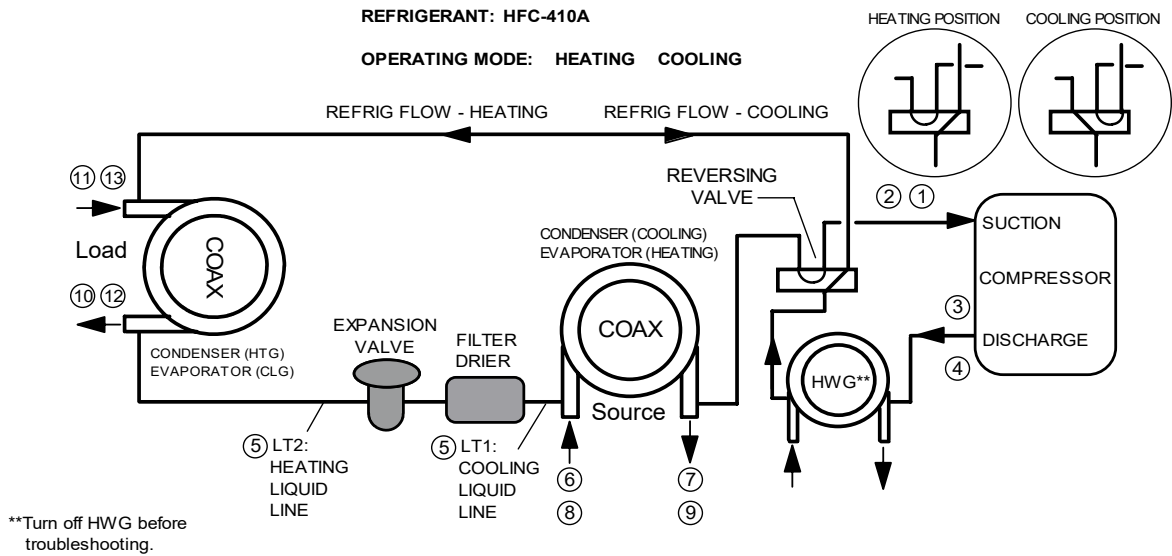

Description	Heating	Cooling	Notes
Voltage			
Compressor Amps			
1 Suction Temp			
2 Suction Press			
2a Saturation Temp			
2b Superheat			
3 Discharge Temp			
4 Discharge Press			
4a Saturation Temp			
4b Subcooling			
5 Liquid Line Temp			
6 Source Water In Tmp			
7 Source Water Out Tmp			Temp Diff. =
8 Source Water In Pres			
9 Source Water Out Pres			
9a Press Drop			
9b Flow Rate GPM [l/s]			
10 Load Water In Temp			
11 Load Water Out Temp			Temp Diff. =
12 Load Water In Pres			
13 Load Water Out Pres			
13a Press Drop			
13b Flow Rate GPM [l/s]			

Heat of Extraction (Absorption) or Heat of Rejection: Fluid Factor: (for Btuh) Fluid Factor: (for kW)

HE or HR = 500 (Water); 485 (Antifreeze) 4.18 (Water); 4.05 (Antifreeze)

_____ Flow Rate x _____ Temp. Diff x _____ Fluid Factor

Notes

Revision History

Date:	Page	Action:
02/24/23	3	Upgraded CXM to CXM2. Introduced DXM2.5

Due to ongoing product improvements, specifications and dimensions are subject to change and correction without notice or incurring obligations. Determining the application and suitability for use of any product is the responsibility of the installer. Additionally, the installer is responsible for verifying dimensional data on the actual product prior to beginning any installation preparations.

Incentive and rebate programs have precise requirements as to product performance and certification. All products meet applicable regulations in effect on date of manufacture; however, certifications are not necessarily granted for the life of a product. Therefore, it is the responsibility of the applicant to determine whether a specific model qualifies for these incentive/rebate programs.



1900 Wellworth Ave., Jackson, MI 49203 • Ph. 517-787-2100 • www.marsdelivers.com



97B0059N04